



Series  
BPX

SIZE 8 COAXIAL CONTACT FRONT RELEASE. REAR REMOVABLE  
CABLE P/N: S280W503-1  
BOEING P/N: S280W554-101

Issue:  
12 FEB. 93

Page  
1 / 1

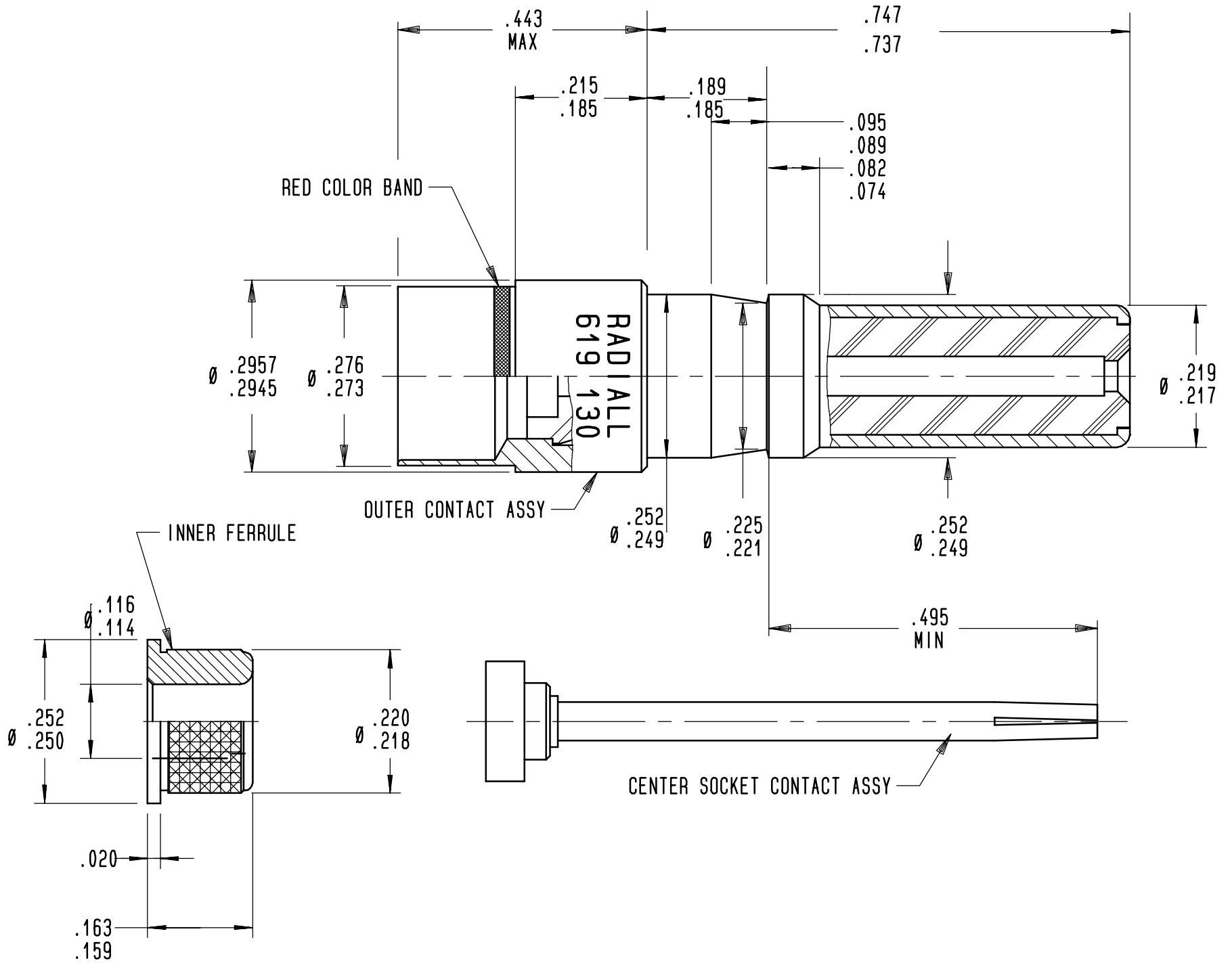

**MATERIALS:**

OUTER CONTACT AND INNER FERRULE: BRASS PER QQ-B-626  
CENTER CONTACT: BERYLLIUM COPPER ALLOY PER QQ-C-530 HEAT TREATED FOR SPRING TINES, ANNEALED ON CRIMP BARREL  
DIELECTRIC AND INSULATING BUSHING: TPFE

**FINISHES (ALL METAL PARTS)**

GOLD PLATE PER MIL-G-45204, TYPE II, GRADE C, CLASS 1: 50 MICROINCHES OVER NICKEL PLATE PER QQ-N-290, CLASS 2

SEE WIRING INSTRUCTIONS: RP8012

This information is given as an indication. In the continual goal to improve our products, we reserve the right to make any modifications judged necessary.

4112\_9311

CREATION				
PEN:				
NOM: JP MACARI	09/01/96	FRONT OF COAX REDRAWN	K. PECHEUX	
DATE: 12 FEB. 93	12/02/93	SUPPRESS $\emptyset$ .101 / .099	BALDYROU	
APPR.:	23/12/92	REDRAWN	JP MACARI	
	Issue	Revisions	Name	Approved